

# Technical Data Sheet Type 28



2/2-way solenoid valve  
 NC - Valve normally closed (as standard)  
 NO - Valve normally open (as option)

Pilot operated diaphragm valve. The mentioned minimum pressure difference between inlet and outlet is necessary for proper operation.  
 In standard (NC) the valve closes with spring power.

■ Solenoid valve for gaseous and liquid media

## TECHNICAL SPECIFICATIONS

Type of control	Pilot operated, pressure difference is required	
Design	Diaphragm design	
Connection	Flanged acc. to EN 1092-1 Form B1/B2 <small>Further flanges like ASME on request</small>	
Installation	Preferable with actuator upright	
Pressure	0,3 - 20 bar (see table on page 2)	
Medium	Clean, neutral, gaseous and liquid media	
Viscosity	22 mm <sup>2</sup> /s	
Temperature range	Medium: -10 °C up to +80 °C Ambient: -10 °C up to +50 °C <small>In consideration of the restrictions described on page 4</small>	
Body material	Cast iron EN-GJL-250 Cast steel GP240 GH Stainless steel 1.4581	
Metallic inner parts	Brass and Stainless steel	
Sealing	NBR, FKM, EPDM	
Supply voltage	AC~ 24V, 110V, 230V DC= 12V, 24V <small>Other supply voltages on request</small>	
Voltage tolerance	-10% / +10%	
Power consumption	.182 = 6,8 Watt    .178 = 5,2 Watt ⚠ .032 = 11 Watt    .148 = 10 Watt ⚠ .012 = 18 Watt	
Protection class	IP65 acc. to DIN 60529	
Duty factor	100% ED-VDE 0580	
Connection type	Plug / Cable	
Ex-proof	acc. to 2014/34/EG(ATEx) <small>Further Ex-proof on request</small>	

## VALVE FEATURES

- Pressure difference is required
- High life time
- Simple compact valve design
- High-quality materials
- Reliable and sturdy sealing elements
- Long-term availability of spare parts

## FUNCTION

NC – non energized closed    NO – non-energized open

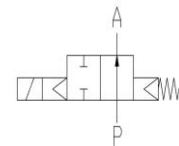
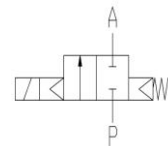

## CERTIFICATES



## ORDERING SYSTEM

Type	Conn.	Housing	Seal	Coil	Option
. 2 8 0 3	/	0 4 0 1	/	. 0 3 2	- N O
01 DN15 02 DN20 03 <b>DN25</b> 04 DN32 05 DN40 06 DN50		04 EN-GJL-250 05 GP240 GH 08 Stainl.st. 1.4581		2 Standard IP65 8 Explosion proof acc. to directive 2014/34/EU (ATEX)	
		01 NBR 02 FKM 06 EPDM			

## TECHNICAL FEATURES

DN	Seat Ø mm	Kv-value m <sup>3</sup> /h	Standard type	max. pressure for coils			max. pressure for coils ATEX		
				.182	.032	.012-NO	.178	.148	.148-NO
15	15	3,9	.2801/..01/	0,3-16	0,3-20	0,3-20	0,3-10	0,3-20	0,3-16
20	20	10,8	.2802/..01/	0,3-16	0,3-20	0,3-20	0,3-10	0,3-20	0,3-16
25	25	13,0	.2803/..01/	0,3-16	0,3-20	0,3-20	0,3-10	0,3-20	0,3-16
32	32	30,0	.2804/..01/	-	0,5-16	0,5-16	-	0,5-16	0,5-13
40	40	32,0	.2805/..01/	-	0,5-16	0,5-16	-	0,5-16	0,5-13
50	50	45,0	.2806/..01/	-	0,5-16	0,5-16	-	0,5-16	0,5-13

The flow rate mentioned in the table applies to the strongest coil.  
Pressure rating for EN-GJL-250 max. 16 bar.

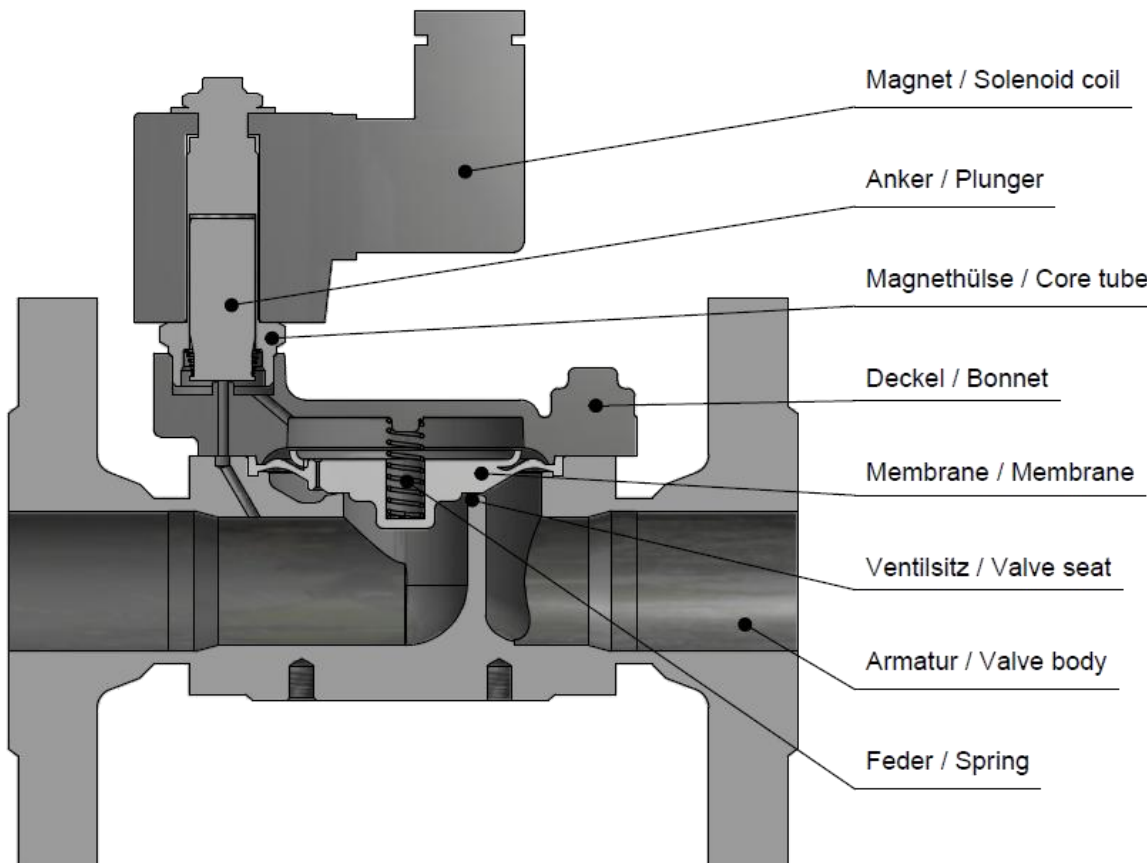

## DIMENSIONS

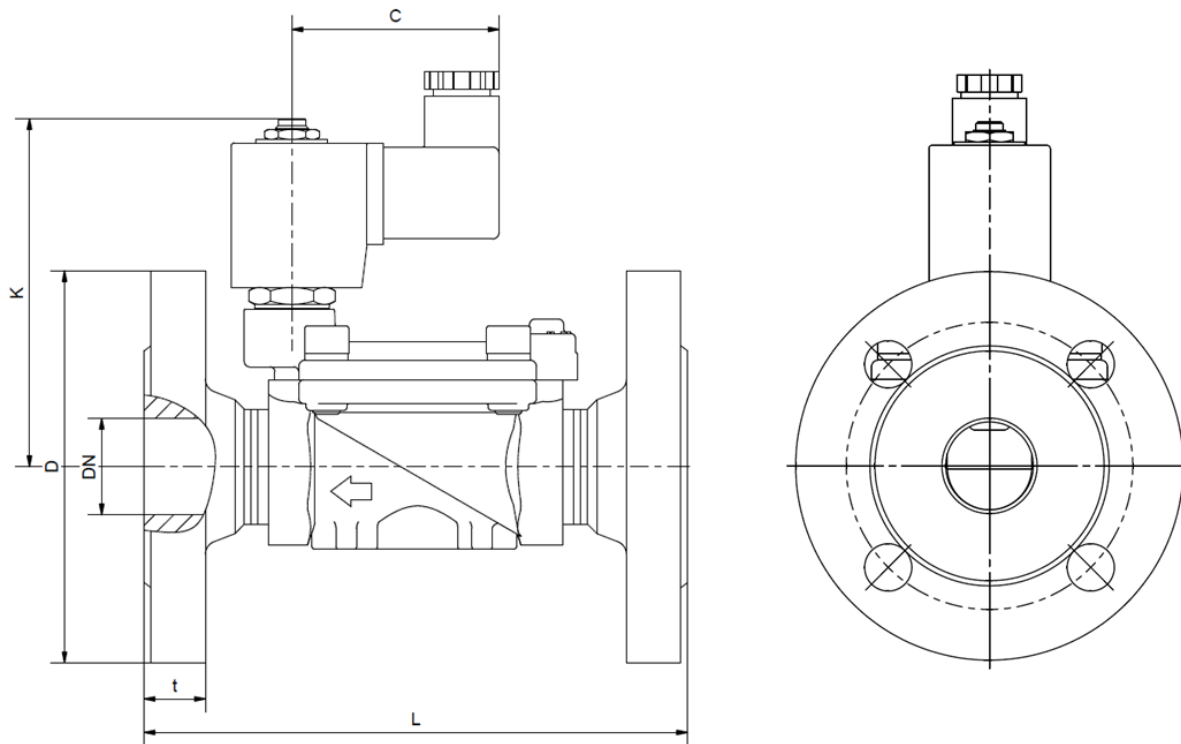

**Type 28**

Coil	.182 / .032 / .012-NO / .148					
Type	2801	2802	2803	2804	2805	2806
DN	15	20	25	32	40	50
C	61	61	61	61	61	61
K	97	105	105	120	120	135
L	130	150	160	180	200	230
t	16	18	18	18	18	20
kg	2,3	3,3	3,8	6,5	7,0	9,5

\*Differing dimension "C" for ATEX-coils

## INFORMATION

- It is imperative to observe the installation and safety instructions in our operating and service manuals.
- For information on our GSR ordering code, please refer to our catalogs. If you have any questions, we will be glad to assist you.
- Required ordering information: valve type, function NC/NO, pressure range, connection, nominal width, medium, flow rate, medium and ambient temperatures, connection voltage.
- **Detailed production-specific drawings and other technical information will be made available when an order is placed**

## PLEASE NOTE

Each individual application decides which valve type is required, the main factor being the resistance of the materials to the operating medium. The correct selection of materials requires knowledge of the concentration, temperature and degree of contamination of the medium. Other criteria include the operating pressure and max. volumetric flow, since, in addition to high temperatures, high pressures and high flow rates must also be taken into account when selecting the materials.

**All materials used for our valves, be it housing, seals or magnets, will be carefully selected in view of the different application areas. Any information given is non-binding and serves for orientation only. No claims under warranty can be derived therefrom.**

## Heating and power of solenoid coils

The GSR default solenoid valves are designed for continuous operation (100% ED = power-on time) under normal operating conditions. The pulling force of a solenoid coil is basically influenced by three elements:

- The self-heating of the magnetic coil
- The medium temperature
- The ambient temperature

GSR solenoid coils are by default designed for a maximum ambient temperature of +35 °C. This specification applies for the maximum allowable operating pressure specified in the data sheet of the corresponding valve, 100% duty cycle and a medium temperature of +80 °C.

A higher ambient temperature is possible, when lower values are applied for the other influencing parameters. When the max. operation pressure and max. ambient temperature of +50 °C is given the medium temperature is not allowed to be higher than max. +50 °C. In addition to that, deviations from the default design temperature range are possible, e.g. when temperature coils or other constructive measures are used. Please contact the GSR headquarters to discuss the specific application.

More precise specifications and technical data with regard to the operating conditions can be found in the data sheets of the solenoid coils and the solenoid valve regarded. Please observe that the surface temperature of a permanently loaded coil can amount up to +120 °C, solely by the self-heating of the coil. The power consumption of our default solenoid valves was calculated to DIN VDE 05820 for a coil temperature of +20 °C.

- The GSR logo is a registered trademark of GSR Ventiltechnik GmbH & Co. KG.
- Note: All texts and images are the property of GSR Ventiltechnik GmbH & Co. KG and must not be replicated or modified, not even in part, without written approval.
- Original products may differ from the product images shown, due to different materials and the like.
- Subject to error and changes.

**Stand: 05.17, MK-MG, Version 1.**