



# Technical Data Sheet Type 2/529



Type 2/529

2/2-way solenoid valve  
 NC - Valve normally closed (as standard)  
 NO - Valve normally open (as option)

Pilot operated piston design. The mentioned minimum pressure difference between inlet and outlet is necessary for proper operation.  
 In standard (NC) the valve closes with spring power.

■ Solenoid valve for high pressure applications

## TECHNICAL SPECIFICATIONS

Type of control	Pilot operated, pressure difference is required
Design	Piston design
Connection	Threaded G1/4 - G2 DIN ISO 228/1 (BSP) Other connections like NPT on request
Installation	Preferable with actuator upright
Pressure	1 - 450 bar (see table page 2)
Medium	Clean, neutral, gaseous and liquid medium
max. viscosity	22 mm <sup>2</sup> /s
Temperature range	Medium: -40 °C bis +80 °C Ambient: -40 °C bis +50 °C In consideration of the restrictions described on page 4
Body material	Stainless steel 1.4571
Metallic inner parts	Stainless steel
Sealing	PTFE, PEEK at the seat
Supply voltage	AC~ 24V, 110V, 230V DC= 12V, 24V Other supply voltages on request
Voltage tolerance	-10% / +10%
Power consumption	.802 = 24 Watt .322 = 30 Watt    .328 = 24 Watt .242 = 46 Watt    .248 = 30 Watt
Type of control	IP65 acc. to DIN 60529
Duty factor	100% ED-VDE 0580
Connection type	Plug / Terminal box
Ex-proof	acc. to 2014/34/EG(ATEx) Further Ex-proof on request

## VALVE FEATURES

- For high pressure applications up to 450 bar
- Pressure difference is required
- High life time
- Simple compact valve design
- High-quality materials
- Reliable and sturdy sealing elements

## FUNCTION

NC – non energized closed      NO – non-energized open

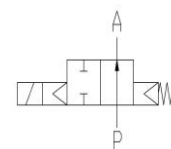
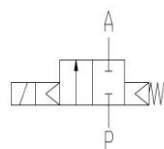

## CERTIFICATES



Special design for a temperature range **up to +180 °C** and as pressure operating valve **up to 600 bar** available  
 Specifications and drawings on request.

## ORDERING SYSTEM

Valve type				Coil system			Options			
2	/	5 2 9	-	2 3	-	0 8 1 5	-	. 3 2 2	-	H A
<b>Connection</b> 21 G 1/4 22 G 3/8 23 G 1/2 24 G 3/4 25 G 1 26 G 1 1/4 27 G 1 1/2 28 G 2				<b>Body material</b> 08 St. steel 1.4581			<b>Seal material</b> 15 PEEK		2 Standard IP65 8 Explosion-proof acc. to directive 2014/34/EU (ATEX)	

# TECHNICAL FEATURES

G	Seat Ø mm	Kv-value m³/h	Standard type	max. pressure for coils			max. pressure for coils ⚠	
				.802	.322	.242	.328	.248
1/4	12	1,8	2/529-21-0815-	1-150	1-300	1-450	1-250	1-350
3/8	12	3,3	2/529-22-0815-	1-150	1-300	1-450	1-250	1-350
1/2	12	3,8	2/529-23-0815-	1-150	1-300	1-450	1-250	1-350
3/4	25	11,5	2/529-24-0815-	1-150	1-220	1-450	1-220	1-350
1	25	13,0	2/529-25-0815-	1-150	1-220	1-450	1-220	1-350
1 1/4	40	22,0	2/529-26-0815-	-	-	1-200	-	1-200
1 1/2	40	24,0	2/529-27-0815-	-	-	1-200	-	1-200
2	50	32,0	2/529-28-0815-	-	-	1-200	-	1-200

The flow rate mentioned in the table applies to the strongest coil.  
Pressure ratings with option manual override may be lower.

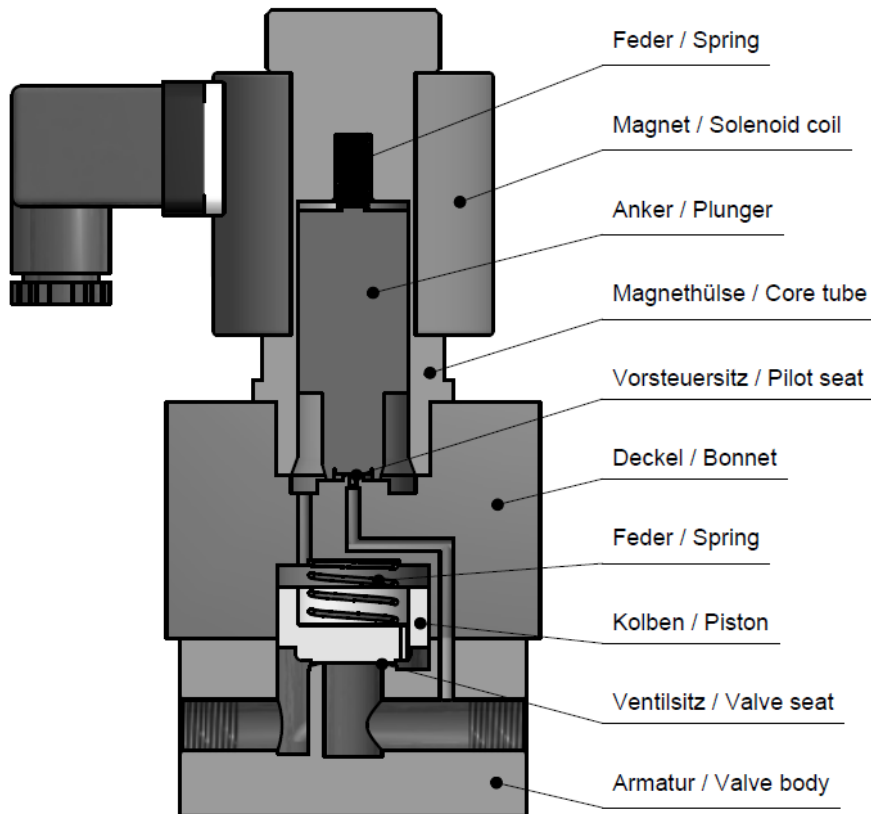

# DIMENSIONS

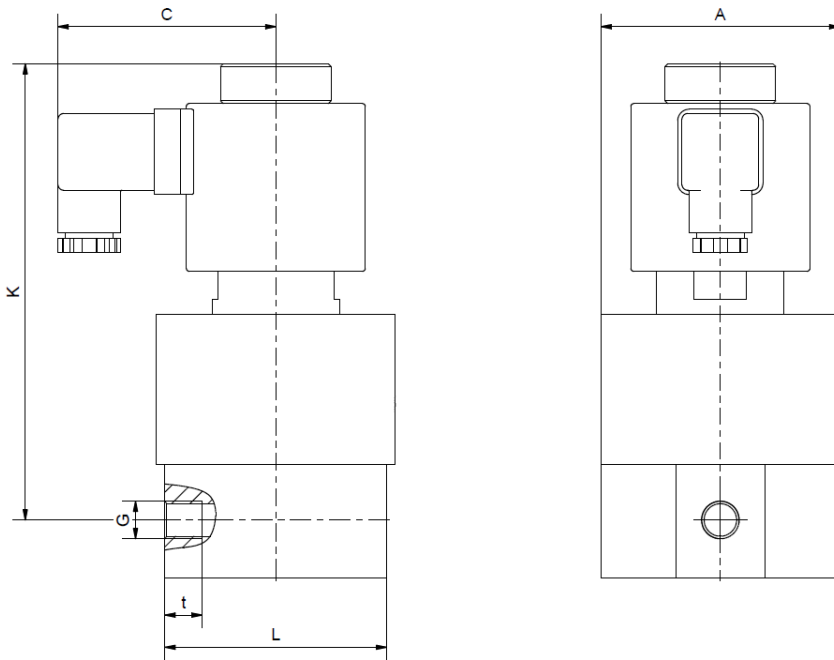

coil	.802					.322/.328*				
Type	2/529-21	2/529-22	2/529-23	2/529-24	2/529-25	2/529-21	2/529-22	2/529-23	2/529-24	2/529-25
G	1/4	3/8	1/2	3/4	1	1/4	3/8	1/2	3/4	1
A	84	84	84	110	110	84	84	84	110	110
C	70	70	70	70	70	77	77	77	77	77
K	143,5	143,5	151,5	159	159	161	161	161	176	176
L	78	78	78	101	101	78	78	78	101	101
t	13	13	15	16	18	13	13	15	16	18
kg	3,8	3,8	4,0	6,6	6,4	5,2	5,2	5,2	7,8	7,7

\*Differing dimension "C" for ATEX coils

coil	.242/.248							
Type	2/529-21	2/529-22	2/529-23	2/529-24	2/529-25	2/529-26	2/529-27	2/529-28
G	1/4	3/8	1/2	3/4	1	1 1/4	1 1/2	2
A	84	84	84	110	110	155	155	170
C	92,5	92,5	92,5	92,5	92,5	92,5	92,5	92,5
K	181,5	181,5	181,5	200	200	228	228	242
L	78	78	78	101	101	140	140	155
t	13	13	15	16	18	22	22	27
kg	6,7	6,6	6,6	9,3	9,3	18,8	18,6	24,6

## INFORMATION

- It is imperative to observe the installation and safety instructions in our operating and service manuals.
- Required ordering information: valve type, function NC/NO, pressure range, connection, nominal width, medium, flow rate, medium and ambient temperatures, connection voltage.
- **Detailed production-specific drawings and other technical information will be made available when an order is placed**

## PLEASE NOTE

Each individual application decides which valve type is required, the main factor being the resistance of the materials to the operating medium. The correct selection of materials requires knowledge of the concentration, temperature and degree of contamination of the medium. Other criteria include the operating pressure and max. volumetric flow, since, in addition to high temperatures, high pressures and high flow rates must also be taken into account when selecting the materials.

**All materials used for our valves, be it housing, seals or magnets, will be carefully selected in view of the different application areas. Any information given is non-binding and serves for orientation only. No claims under warranty can be derived therefrom.**

## Heating and power of solenoid coils

The GSR default solenoid valves are designed for continuous operation (100% ED = power-on time) under normal operating conditions. The pulling force of a solenoid coil is basically influenced by three elements:

- The self-heating of the magnetic coil
- The medium temperature
- The ambient temperature

GSR solenoid coils are by default (non-ATEX) designed for a maximum ambient temperature of +35 °C. This specification applies for the maximum allowable operating pressure specified in the data sheet of the corresponding valve, 100% duty cycle and a medium temperature of +80 °C.

A higher ambient temperature is possible, when lower values are applied for the other influencing parameters. When the max. operation pressure and max. ambient temperature of +50 °C is given the medium temperature is not allowed to be higher than max. +50 °C. In addition to that, deviations from the default design temperature range are possible, e.g. when temperature coils or other constructive measures are used. Please contact the GSR headquarters to discuss the specific application.

More precise specifications and technical data with regard to the operating conditions can be found in the data sheets of the solenoid coils and the solenoid valve regarded. Please observe that the surface temperature of a permanently loaded coil can amount up to +120 °C, solely by the self-heating of the coil. The power consumption of our default solenoid valves was calculated to DIN VDE 05820 for a coil temperature of +20 °C.